

DATENBLATT

ADI12-8(FIT)GY

HABEN SIE FRAGEN ODER WÜNSCHEN SIE EIN INDIVIDUELLES ANGEBOT?

Unser Team berät Sie gerne persönlich.

TELEFON + 49 (0) 81 41/36 97-0

TELEFAX + 49 (0) 81 41/36 97-30

E-MAIL info@plug-in.de

WWW.PLUG-IN.DE

ADRESSE

Am Sonnenlicht 5

D-82239 Alling bei München





* Specifications, color and design of the products are subject to change without notice.

Features

The input range is common to different channels, and can be selected from four input ranges, including unipolar and bipolar ranges.

The ability to accommodate differential input permits the accurate measurement of voltage values over long distances from the signal source and even under a considerable potential difference.

A rotary switch allows you to set device IDs to help you keep track of device numbers.

The system incorporates a screwless connector plug that allows you to easily attach and detach wires without using any special tools.

Similar to other F&elt series products, the system, in the module itself, incorporates a 35-mm DIN rail mounting mechanism as a standard item. A connection to a controller module can be effected on a lateral, stack basis in a unique configuration, which permits a simple, smart system configuration without the need for a backplane board.

Congratulations on your recent purchase of an Insulator Digital Input Module.

By converting external analog voltage signals into digital data, this product can process them inside the F&elt series controller module < CPU-CAxx(FIT)GYGY, CPU-SBxx(FIT)GY etc >.

The insulation between external signals and the Controller Module permits the use of the Controller Module without compromising the communications features of the latter.

Specification

Specifications

Item	Specifications
Analog input section	
Input format	Bus-isolated voltage input
Input range	Bipolar $\pm 10V$, $\pm 5V$ Unipolar 0 - 10V, 0 - 5V
Maximum input voltage	$\pm 20V$
Input impedance	$1M\Omega$ (Min.)
Input channel	Differential input, 8 channels
Resolution	12-bit
Non-linear error *1	$\pm 3LSB$
Conversion rate	Number of conversion channels x $10\mu\text{sec}$ + $20\mu\text{sec}$
Data buffer	8-Word
Interrupt	Either IRQ5 or IRQ7 or IRQ9 *2
Internal sampling timer	$10\mu\text{sec}$ - $1,073,741,824\mu\text{sec}$ *3
Common section	
Internal power consumption	$5VDC \pm 5\%$ 350mA (Max.)
Maximum distance of signal extension	1.5m
External dimensions (mm)	25.2 (W) x 64.7 (D) x 94.0 (H) (exclusive of protrusions)
Weight (module itself)	100g
Module connection method	Stack connection by the connector that is provided with the side of module
Module installation method	One-touch connection to 35mm DIN rails (standard connection mechanism provided in the system)
Applicable wire	AWG 28 - 20
Applicable plug	FK- MC 0,5/12-ST-2,5 (made by Phoenix Contact Corp.)

*1 When the environment temperature is near 0°C or 50°C, the non-linearity error may become larger.

*2 Available only when this product is connected to the CPU-SBxx(FIT)GY.

*3 When this product is connected to the ADI12-8(USB)GY, the sampling timer built in the ADI12-8(USB)GY is used. The setting range is from 1,000 - 1,073,741,824 μsec .

⚠ CAUTION

When connecting one of the modules to a controller module, the internal power consumption should be taken into account. If the total current exceeds the capacity of the power supply unit, the integrity of the operation cannot be guaranteed. For further details, please see the Controller Module manual.

Depending upon the specific controller module that is used, some of the functions are not supported.

Installation Environment Requirements

Parameter	Requirement description
Operating temperature	0 - 50°C
Storage temperature	-10 - 60°C
Humidity	10 - 90% RH (No condensation)
Floating dust particles	Not to be excessive
Corrosive gases	None
Line-Noise resistance	Line-noise AC line/2kV, Signal line/1kV (IEC1000-4-4Level 3, EN61000-4-4Level 3)
	Static electricity resistance Contact discharge/4kV (IEC1000-4-2Level 2, EN61000-4-2Level 2) Atmospheric discharge/8kV (IEC1000-4-2Level 3, EN61000-4-2Level 3)
Vibration resistance	Sweep 10 - 57Hz/semi-amplitude 0.15mm, 57 - 150Hz/2.0G
	resistance 80minutes each in X, Y, and Z directions (JIS C0040-compliant, IEC68-2-6-compliant)
Impact resistance	15G, half-sine shock for 11ms in X, Y, and Z directions (JIS C004-compliant, IEC68-2-27-compliant)
Certification	RoHS,CE EMC,FCC,VCCI

Packing List

Module ...1
 First Step Guide ...1
 CD-ROM [F&EIT Series Setup Disk] *1...1
 Interface connector plugs ...2
 Warranty Certificate...1
 Serial number label...1

*1 The CD-ROM contains various software and User's Manual.

Physical Dimensions

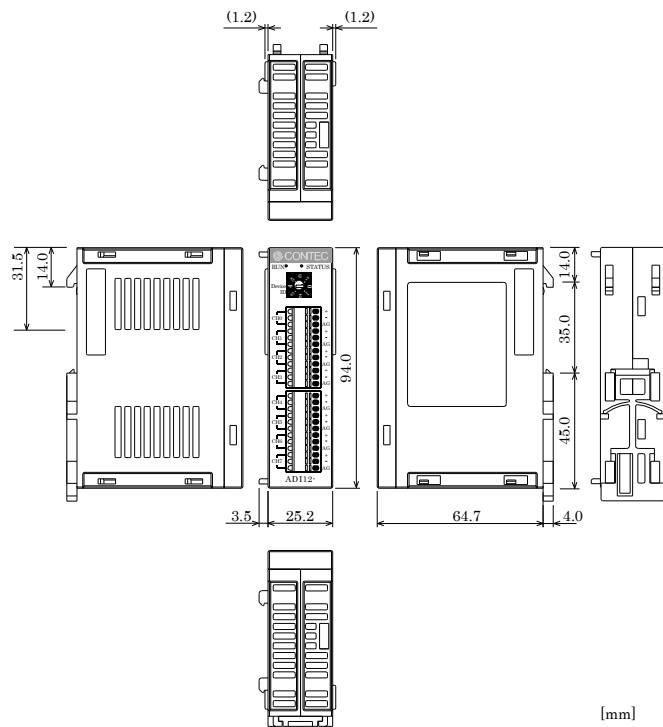

How to Connect an Interface Connector

When connecting the Module to an external device, you can use the supplied connector plug. When wiring the Module, strip off approximately 7 - 8 mm of the covering for the cable, and insert the bare wire by pressing the orange button on the connector plug. Releasing the orange button after the wire is inserted to fix the cable. Compatible wires are AWG 28 - 20.

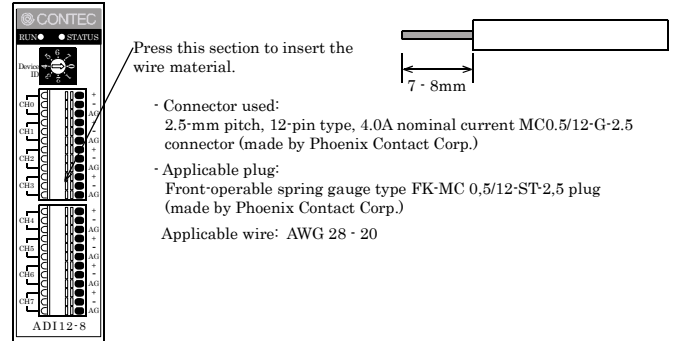

- Connector used:
2.5-mm pitch, 12-pin type, 4.0A nominal current MC0.5/12-G-2.5 connector (made by Phoenix Contact Corp.)
- Applicable plug:
Front-operable spring gauge type FK-MC 0,5/12-ST-2,5 plug (made by Phoenix Contact Corp.)
- Applicable wire: AWG 28 - 20

CAUTION

Removing the connector plug by grasping the cable can break the wire.

Signal Layout on the Interface Connector

The Module can be connected to an external device using a 12-pin (1 group) connector that is provided on the Module face.

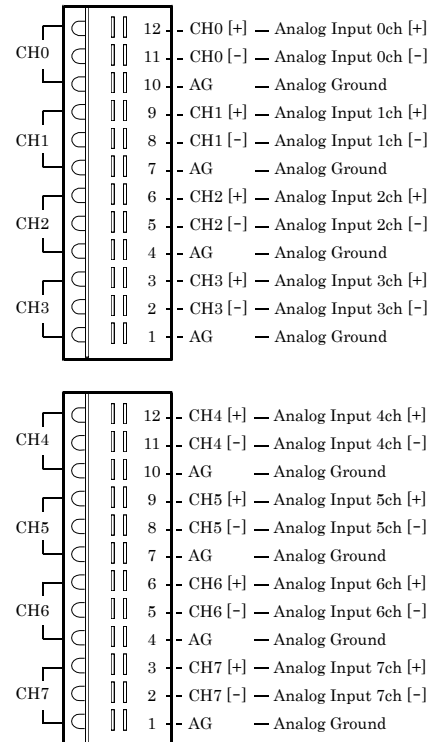

Setting a Device ID

The controller module distinguishes and keeps track of the modules that are connected to it by assigning device IDs to them. Each module, therefore, should be assigned a unique ID.

A Device ID can be assigned in a 0 - 7 range, so that a maximum of eight modules can be distinguished.

To connect this product to the ADI12-8(USB)GY, assign a device ID between 1 and 3.

The factory setting for the Device ID is [0].

Setup Method

A device ID can be set by turning the rotary switch on the device face.

To set a device ID, turn the switch knob.

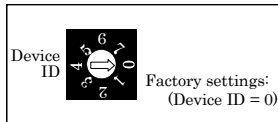

Block Diagram

