

N Series for USB
Multifunction DAQ Unit (8ch AI, 2ch AO, 16ch DIO)
AIO-120802LN2-USB



* Specifications, color and design of the products are subject to change without notice.

Features

- Multi-function

Analog I/O can be implemented in a compact system. The series consists of two different models from which you can select the best model to suit your application.

The < AIO-120802LN2-USB > contains the analog input (12bit, 8ch), analog output (12bit, 2ch).

All two models include bi-directional digital inputs / outputs (16points, TTL level) and a counter (32bit 1ch, TTL level). You can select the input/output by the application software in eight signals units.

- Analog I/O can be synchronized with an internal timer or external clock

Analog I/O can both be performed at fixed time intervals and synchronized with an external signal.

- Digital filter function to prevent wrong recognition of external signal chattering is provided

This product has analog input / output control signal, digital input signal and digital filter function to prevent it from chattering in counter input signal. (Excluding external clock input signal, counter gate signal)

- Buffer memory available for background processing independent of software

This product include buffer memory (1K Word each for analog input and output) which can be used in either FIFO or ring format. This allows analog I/O to be performed independently of the operating state of the PC or software.

- Software-based adjustment function

Adjustment of analog input can be all performed by software. Apart from the adjustment information prepared before shipment, additional adjustment information can be stored according to the use environment.

- Compact design not restricting installation location (188.0(W) x 78.0(D) x 30.5(H))

Compact design of 188.0(W) x 78.0(D) x 30.5(H) does not require special installation location.

- Compatible to USB2.0/USB1.1

Compatible to USB2.0/USB1.1 and capable to achieve high speed transfer at HighSpeed (480 Mbps).

- Diverse installations such as screw fastening, magnet(option), DIN rail are possible

Installation on the floor / wall /ceiling is possible by screw fastening, magnet, rubber feet, etc. In addition, DIN rail mounting mechanism is equipped as standard with the product, making it easy to install the product within the panel or the device.

This product is a USB2.0-compliant analog I/O unit that extends the analog I/O function of USB port of PCs.

Compact design not restricting installation location (188.0(W) x 78.0(D) x 30.5(H)) makes it easy to install the product within the panel or device using DIN rail mounting jigs, or on the floor or wall.

Windows/Linux device driver is supported with the product.

- * The contents in this document are subject to change without notice.
- * Visit the CONTEC website to check the latest details in the document.
- * The information in the data sheets is as of September, 2025.

- Easy-to-wire terminal connector adopted

Adoption of terminal connector (with screws) enables to achieve easy wiring.

- Windows/Linux support device driver

Using the device driver API-TOOL makes it possible to create applications of Windows/Linux. In addition, a diagnostic program by which the operations of hardware can be checked is provided.

Included Items

- Product...1
- Interface connector...5
- USB Cable(1.8m)...1
- USB Cable Attachment...1
- Please read the following...1

Support Software

Name	Contents	How to get
Windows Version Analog I/O Driver software API-AIO(WDM)	The API-AIO(WDM) is the Windows version driver software that provides products in the form of Win32 API functions (DLL). Various sample programs such as Visual Basic and Visual C++, etc and diagnostic program useful for checking operation is provided.	Download from the CONTEC website *1
Linux Version Analog I/O Driver software API-AIO(LNX)	This is the Linux version driver software provided in API function formats. The software includes various sample programs such as gcc (C, C++) and Python programs.	Download from the CONTEC website *1
Coming soon Software Development Tool Kits (SDK) and Support Software	In addition to the device drivers, we offer many software programs for using CONTEC devices in an easier manner.	Download from the CONTEC website *2

*1 Download the files from the following URL
<https://www.contec.com/download/>

*2 For supported software, search the CONTEC website for this product and view the product page.
<https://www.contec.co>

Specifications

Function specification

Item	Specification
Analog input	
Isolated specification	Un-Isolated
Input type	Single-Ended Input or Differential Input
Number of input channels	8channels (Single-Ended Input), 4channels (Differential Input)
Input range	Bipolar $\pm 10V$, $\pm 5V$, $\pm 2.5V$ or Unipolar $0 - +10V$
Absolute max. input voltage	$\pm 15V$
Input impedance	$1M\Omega$ or more
Resolution	12bit
Non-linear error *1*2	$\pm 20LSB$
Conversion speed	$5\mu sec/ch$ (Max) *3 [200KSPS] *4*5
Buffer memory	1K data FIFO or 1K data RING
Conversion start trigger	Software / external trigger
Conversion stop trigger	Number of sampling times / external trigger / software
External start signal	TTL level (Rising or falling edge can be selected by software)
External stop signal	TTL level (Rising or falling edge can be selected by software)
External clock signal	TTL level (Rising or falling edge can be selected by software)
Analog output	
Isolated specification	Un-Isolated
Number of output channels	2ch
Output range	Bipolar $\pm 10V$, $\pm 5V$ or Unipolar $0 - +10V$, $0 - +5V$
Output current ability	$\pm 3mA$
Output impedance	1Ω or less
Resolution	12bit
Non-linear error *1*2	$\pm 20LSB$
Conversion speed	$12\mu sec$ (Max) [83KSPS] *4*5
Buffer memory	1K data FIFO or 1K data RING
Conversion start trigger	Software / external trigger
Conversion stop trigger	Number of sampling times / external trigger/software
External start signal	TTL level (Rising or falling edge can be selected by software)
External stop signal	TTL level (Rising or falling edge can be selected by software)
External clock signal	TTL level (Rising or falling edge can be selected by software)
Digital I/O	
Number of I/O channels	16-bit input lines, 8-bit input/output lines, 16-bit output lines (programmable)
I/O signal level	TTL level (positive logic)
Counter	
Number of channels	1channels
Counting system	Up count
Max. count	FFFFFFFF (Binary data, 32bit)
Number of external inputs	TTL level : 2 (Gate/Up)ch, Gate (High level), Up (Rising edge)
Number of external outputs	TTL level : 1ch, Count match output (positive logic, pulse output)
Frequency response	5MHz (Max)
USB	
Bus specification	USB Specification 2.0/1.1 standard
USB transfer rate	12Mbps (Full-speed), 480Mbps (High-speed) *6
Power supply	Bus power
Common section	
Number of terminals used at the same time	127 terminals (Max) *7
Power consumption	5VDC 500mA (Max)
Physical dimensions (mm)	188(L) x 78(D) x 30.5(H) (No protrusions)
Weight	300g (Not including the USB cable, attachment)
Attached cable length	USB Cable 1.8m

- *1 A linearity error approximately 0.1% of full-range may occur when operated at 0°C or 50°C ambient temperature. The error can be reduced by calibrating under the actual temperature conditions.
- *2 When using a signal source with a built-in high-speed operational amp.
- *3 The required time is indicated in the analog to digital translation of one channel. When AD of two or more channels is converted, time of the a few minutes of the channel is necessary.
Conversion time = Number of conversion channels x 2 μsec
- *4 SPS = Samplings Per Second. The number of data that can be converted in one second is shown.
- *5 This numerical displays the conversion speed for A/D, D/A converter. The minimum executable sampling cycle depends on the operating condition of the terminal.
- *6 The USB transfer speed depends on the host PC environment used (OS and USB host controller).
- *7 As a USB hub is also counted as one device, you cannot just connect 127 USB terminals.

Installation Environment Requirements

Item	Specifications
Operating ambient temperature *1	0 - 50°C
Operating ambient humidity *1	10 - 90%RH (No condensation)
Floating dust particles	Not to be excessive
Corrosive gases	None
Standard	VCCI Class A, FCC Class A, CE Marking (EMC Directive Class A, RoHS Directive), UKCA

*1 To suppress the heating, ensure that there are spaces for ventilation (about 5cm) around this product.

Physical Dimensions

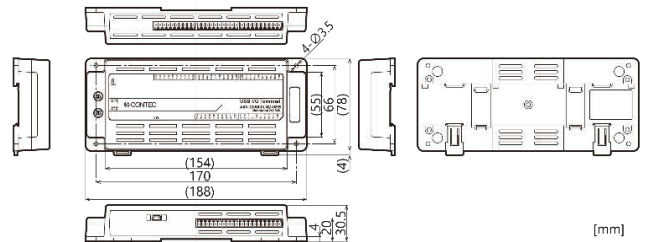

Circuit Block Diagram

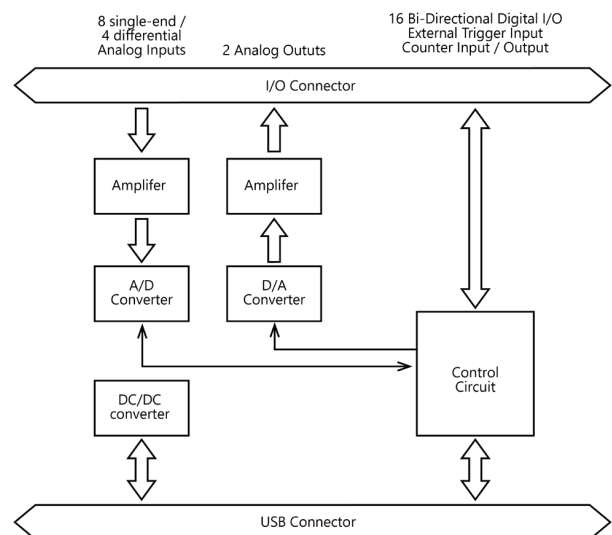

CAUTION

- Do not connect any of the outputs and power outputs to the analog or digital ground. Neither connect outputs to each other. Doing either can result in a fault.
- If analog and digital ground are shorted together, noise on the digital signals may affect the analog signals. Accordingly, analog and digital ground should be separated.
- Leave "Reserved" pins unconnected. Connecting these pins may cause a fault in the product.

Connecting Analog Input Signal

The procedure for connecting analog signals depends on whether the analog input signals are single-ended or differential. The sections below describe how to connect the signals using flat cable and shielded cable.

Single-ended Input

Connection example with flat cable

The following figure shows an example of flat cable connection. Connect separate signal and ground wires for each analog input channel on interface connector.

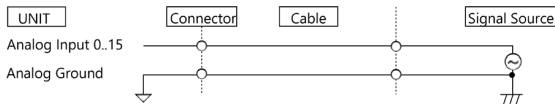

Connection example with shield cable

The following figure shows an example of shield cable connection. Use shielded cable if the distance between the signal source and unit is long or if you want to provide better protection from noise. For each analog input channel on interface connector, connect the core wire to the signal line and connect the shielding to ground.

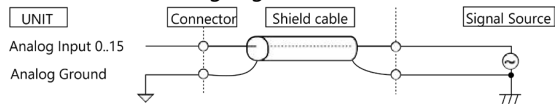

CAUTION

- If the signal source contains over 500 kHz signals, the signal may affect the cross-talk noise between channels.
- If the unit and the signal source receive noise or the distance between the unit and the signal source is too long, data may not be input properly.
- An input analog signal should not exceed the maximum input voltage (relate to the product analog ground). If it exceeds the maximum voltage, the unit may be damaged.
- Connect all the unused analog input channels to analog ground.
- In the channel switching, the multiplexer does the electrical charge and discharge on the internal capacitor according to the signal voltage. Therefore, the voltage from the previous switching state may go into the next channel. It might cause the error of the signal source action. If this occurs, insert a high-speed amplifier as a buffer between the signal source and the analog input pin to reduce the fluctuation.
- An input pin may fail to obtain input data normally when the signal source connected to the pin has high impedance. If this is the case, change the signal source to one with lower output impedance or insert a high-speed amplifier buffer between the signal source and the analog input pin to reduce the effect.

Differential Input

Connection example with flat cable

The following figure shows an example of flat cable connection. For each analog input channel on interface connector, connect the "+" input to the signal and connect the "-" input to the signal source ground. Also connect the analog ground on the unit to the signal source ground.

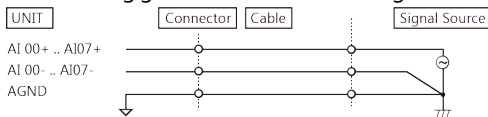

Connection example with shield cable

The following figure shows an example of shielded cable connection. Use shielded cable if the distance between the signal source and unit is long or if you want to provide better protection from noise. For each analog input channel on interface connector, connect the "+" input to the signal and connect the "-" input to the signal source ground. Also connect the analog ground on the unit and the signal source ground to the shielding.

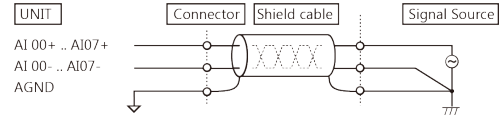

CAUTION

- If the signal source contains over 500 kHz signals, the signal may affect the cross-talk noise between channels.
- When the analog ground is not connected, the conversion data is not determined.
- If the unit and the signal source receive noise or the distance between the unit and the signal source is too long, data may not be input properly.
- An input analog signal should not exceed the maximum input voltage (relate to the unit analog ground). If it exceeds the maximum voltage, the unit may be damaged.
- Connect all the unused analog input channels to analog ground.
- In the channel switching, the multiplexer does the electrical charge and discharge on the internal capacitor according to the signal voltage. Therefore, the voltage from the previous switching state may go into the next channel. It might cause the error of the signal source action. If this occurs, insert a high-speed amplifier as a buffer between the signal source and the analog input pin to reduce the fluctuation.
- An input pin may fail to obtain input data normally when the signal source connected to the pin has high impedance. If this is the case, change the signal source to one with lower output impedance or insert a high-speed amplifier buffer between the signal source and the analog input pin to reduce the effect.

Connecting Analog Output Signal

This section shows how to connect the analog output signal by using a flat cable or a shield cable.

Connection example with flat cable

The following figure shows an example of flat cable connection. Connect the signal source and ground to the interface connector analog output.

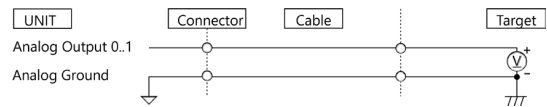

Connection example with shield cable

The following figure shows an example of shield cable connection. Use shield cable if the distance between the signal source and this product is long or if you want to provide better protection from noise. For the interface connector analog output, connect the core wire to the signal line and connect the shielding to ground.

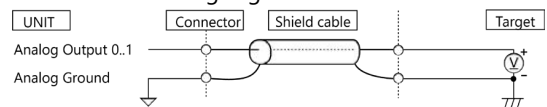

CAUTION

- If this product or the connected wire receives noise, or the distance between this product and the target is long, data may not be outputted properly.
- For analog output signal, the current capacity is ±3mA (Max). Check the specification of the connected device before connecting this product.
- Do not short the analog output signal to analog ground, digital ground. Doing so may damage this product.
- Analog output signal outputs hundreds of micro voltages when USB cable is inserted.

Connecting Digital I/O Signals

The following sections show examples of how to connect digital I/O signals. All the I/O signals are TTL level, and input or output can be set in 8 bit unit by software.

I/O Circuit

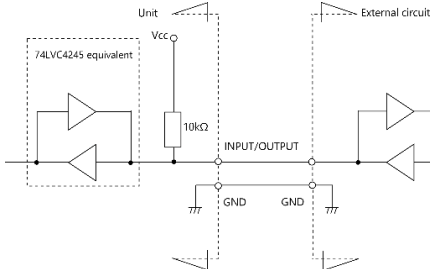

Example of Connection(Connection Example Using DIO00 for Input and DIO08 for Output)

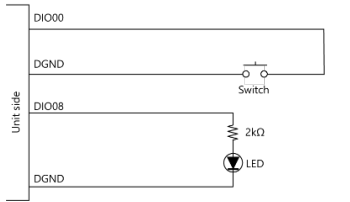

When switch is "ON", the corresponding bit is "0". When switch is "OFF" in contrast, the corresponding bit is "1". When "1" is output to a relevant bit, the corresponding LED comes on. When "0" is output to the bit, in contrast, the LED goes out.

CAUTION

Take care not to short the outputs to digital ground as this may cause a fault.

Counter signals and Control signals Connection

The following sections show examples of how to connect counter I/O signals, and other control I/O signals (external trigger input signals, sampling clock input signals, etc.).

All the counter I/O signals and control signals are TTL level signals.

Counter input and Control input Connection

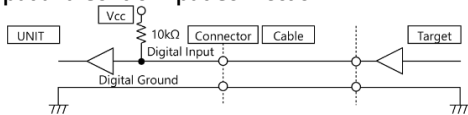

Counter Output Connection

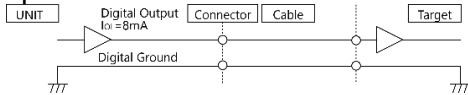

About the counter input control signal

Counter Gate Control Input (refer to the chapter 3 Connector Pin Assignment) acts as an input that validate or invalidate the input of an external clock for the counter. This function enables the control of an external clock input for the counter. The external clock for the counter is effective when input is "High" and invalid when input is "Low". If unconnected, it is a pull-up in this product and remains "High". Therefore the external clock for the counter is effective when the counter gate control input is not connected.

CAUTION

- Do not short the output signals to analog ground, digital ground, and/or power line. Doing so may damage the product.
- If connected to each output, a pull-up resistor must be about 10kΩ to pull up with a 5V power source.

Component Name

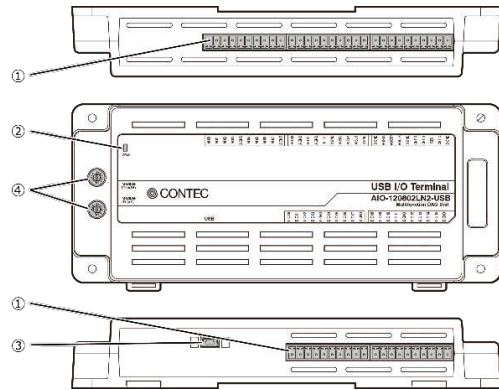

No.	Name	No.	Name
1	Interface Connector	3	USB port (mini B Connector)
2	LED Indicator	4	Setting Switches

Differences between this product and our earlier models

Item	AI0-120802LN-USB	AI0-120802LN2-USB
Location and orientation of the USB connector	Front side	Back side
Individual recognition method	Built-in ID	Set with the rotary switch
Digital input/output circuit logic IC	74LVT244	74LVC4245 equivalent
Counter output signal IOL	24mA	8mA
Power consumption	450mA(Max.)	500mA(Max.)

Location and orientation of the USB connector

Please note that the USB connector on this product is reversed from the conventional product.

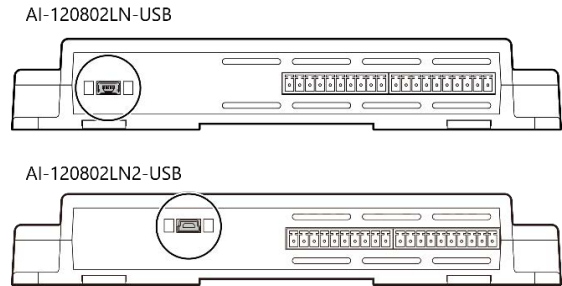

Individual recognition method

When two or more devices of the same product are connected to the same PC, the method of individual recognition differs from the conventional product. For this product, use the rotary switch on the bottom of the unit to select the device ID.

"x16" and "x1" represent upper four bits and lower four bits of Module ID respectively.

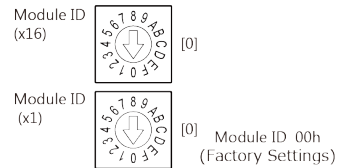

Module ID	Description
00 - 7Fh	It is a setting range for module IDs.
FFh	This is used only when upgrading the firmware.

⚠ CAUTION

-
- When setting with Module ID(x1) = F, Module ID(x16) = F, Module ID is only used for upgrading the firmware. This setting cannot be used to distinguish or keep tracks of the devices.
-

Other differences

- Compatible with Windows 10 or later (For details, please refer to Help or Online Help.
- When replacing from the old product, it is necessary to update the device driver API-AIO (WDM)/API-AIO (LNX) to the corresponding version.