

# SCM7B35



## Isolated 2-Wire Transmitter Interface Modules With Loop Power

### Description

SCM7B35 current input modules accept input signals in the 4-20mA range from the field and provide a high-level voltage output to the process control system (Figure 1). Current to voltage conversion occurs internal to the module, which is factory calibrated to ensure the highest accuracy.

Loop power is provided by the module, enabling a 2-wire transmitter to be directly connected without the need for a separate dc power supply for the 2-wire transmitter.

These modules incorporate a five-pole filtering approach to maximize both time and frequency response by taking advantage of both Thomson (Bessel) and Butterworth characteristics. One pole of the filter is on the field side of the isolation barrier; four are on the process control system side.

After the initial field-side filtering, the input signal is chopped by a proprietary chopper circuit and transferred across the transformer isolation barrier, suppressing transmission of common mode spikes and surges. The signal is then reconstructed and filtered for process control system output.

Modules accept a wide 18 - 35VDC power supply range (+24VDC nominal). Their compact packages (2.13"x1.705"x0.605" max) save space and are ideal for high channel density applications. They are designed for easy DIN rail mounting using any of the -DIN backpanels.

### Features

- 2-Wire Transmitter Interface
- Accepts 4-20mA Signals
- Provides an Isolated +24VDC Supply to Power the Loop
- Provides High-Level Voltage Outputs
- 1500Vrms Transformer Isolation
- Accuracy,  $\pm 0.03\%$  of Span Typical,  $\pm 0.1\%$  Max
- ANSI/IEEE C37.90.1 Transient Protection
- 120Vrms Input Protection
- 105dB CMRR
- Easy DIN Rail Mounting
- CSA C/US Certified
- CE and ATEX Compliant

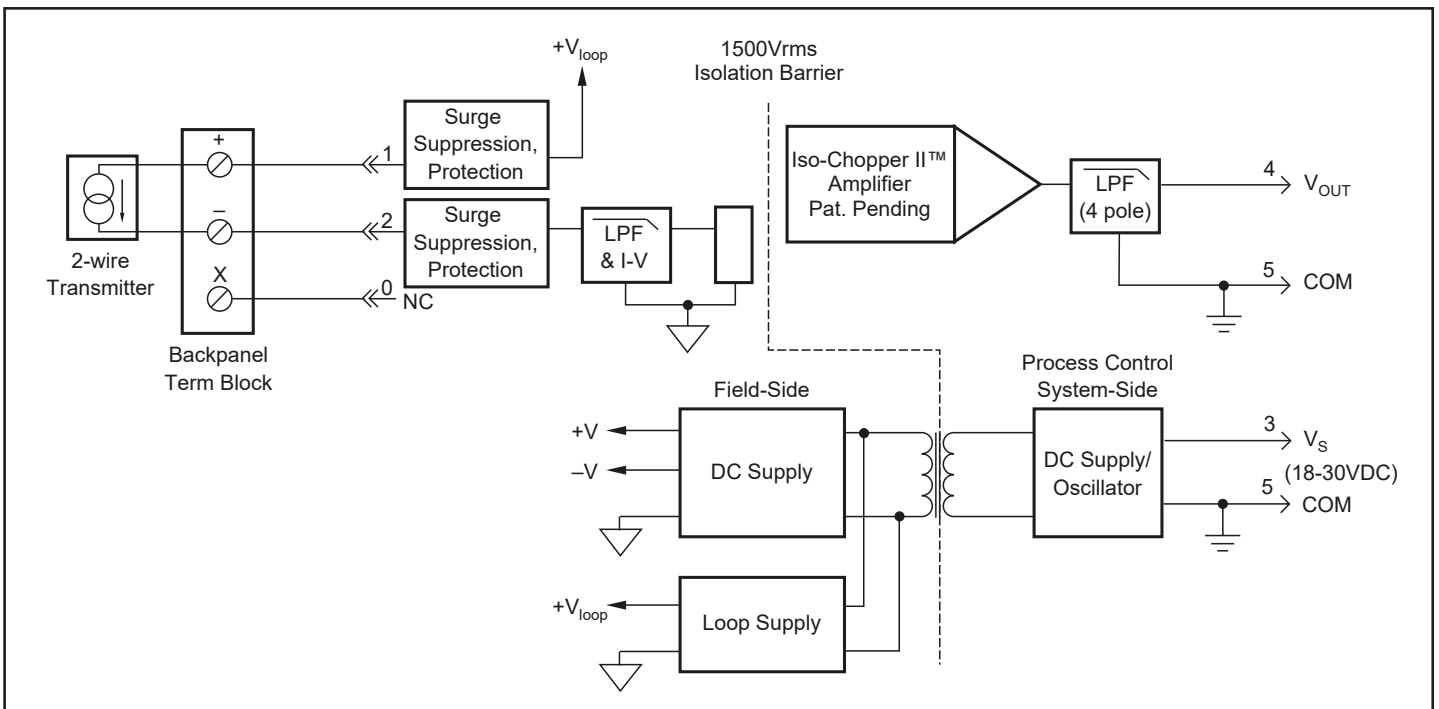

Figure 1: SCM7B35 Block Diagram

**Specifications** Typical\* at 25°C and +24VDC

Module	SCM7B35
Input	
Signal Range	4-20mA
Protection	
Continuous	120Vrms max
Transient	ANSI/IEEE C37.90.1
Loop Voltage <sup>(1)</sup>	+24VDC
Output	
Signal Range <sup>(2)</sup>	See Ordering Information
Effective Available Power <sup>(2)</sup>	40mW
Resistance	<1Ω
Protection	Continuous Short to Ground
Voltage/Current Limit	±16V, ±14mA
CMV (Input-to-Output)	
Continuous	1500Vrms
Transient	ANSI/IEEE C37.90.1
CMRR (50 or 60Hz)	105dB
Accuracy <sup>(3)</sup>	±0.03% Span typical, ±0.1% Span max
Linearity <sup>(4)</sup>	±0.01% Span typical, ±0.02% Span max
Stability (-40°C to +85°C)	
Gain	±40ppm/°C
Input Offset	N/A <sup>(5)</sup>
Output Offset	±0.003% Span/°C
Noise	
Peak at 5MHz B/W	5mV
RMS at 10Hz to 100kHz B/W	500μV
Peak at 0.1Hz to 10Hz B/W	3μV RTI <sup>(6)</sup>
Frequency and Time Response	
Bandwidth, -3dB	100Hz
NMR (-3dB at 100Hz)	80dB per Decade above 100Hz
Step Response, 90% Span	5ms
Supply Voltage	18 to 30VDC
Current <sup>(2)</sup>	56mA
Sensitivity	±0.0002%/V <sub>S</sub>
Mechanical Dimensions (h)(w)(d)	2.13" x 1.705" x 0.605" max (54.1mm x 43.3mm x 15.4mm max)
Environmental	
Operating Temperature Range	-40°C to +85°C
Storage Temperature Range	-40°C to +85°C
Relative Humidity	0 to 95% Noncondensing
Emissions EN61000-6-4	ISM, Group 1
Radiated, Conducted	Class A
Immunity EN61000-6-2	ISM, Group 1
RF	Performance A ±0.5% Span Error
ESD, EFT	Performance B

## NOTES:

\*Contact factory or your local Dataforth sales office for maximum values.

(1) +24V will be supplied to the loop for an open loop condition. Approximately +22V to +16V will be supplied for a corresponding 4mA to 20mA input. Loop voltage is independent of supply voltage.

(2) Output Range and Supply Current specifications are based on minimum output load resistance. Minimum output load resistance is calculated by  $V_{OUT}^2/P_E$ , where  $P_E$  is the Output Effective Available Power that guarantees output range, accuracy, and linearity specifications.

(3) Accuracy includes the effects of repeatability, hysteresis, and linearity.

(4) Linearity is calculated using the best-fit straight line method.

(5) Input offset term included in output offset specification.

(6) RTI = Referenced to Input.

**Ordering Information**

Model	Input Range	Output Range
SCM7B35-01	4 to 20mA	+1 to +5V
SCM7B35-01A	4 to 20mA	0 to +5V
SCM7B35-01D	4 to 20mA	0 to +10V
SCM7B35-02	4 to 20mA	+2 to +10V