

# Datenblatt

Haben Sie Fragen oder wünschen Sie ein individuelles Angebot? **Unser Vertriebsteam berät Sie gerne!**

Kontaktieren Sie uns per Telefon, Fax oder E-Mail und nennen Sie uns Ihre Wünsche:

Ringstr. 48 • D-82223 Eichenau

Tel.: +49 (0) 8141/36 97-0

Fax: +49 (0) 8141/36 97-30

E-Mail: [info@PLUG-IN.de](mailto:info@PLUG-IN.de)

**[www.PLUG-IN.de](http://www.PLUG-IN.de)**



# DNR-6-1G

## HalfRACK™ Ethernet I/O

- Allows the installation of up to 6 I/O boards
- Over 30 different I/O boards available
- Front-loading I/O boards for rapid reconfiguration or repair
- Two independent Gigabit (1000/100/10Base-T) Ethernet Interfaces
- Two, independent IP addresses on separate connectors
- Inter RACK Sync Interface
- Compact : 5.25" x 6.2" x 10.5" (3U) provides 6 I/O slots
- Up to 150 A/D, 288 DIO, 192 D/A, 72 ARINC-429 channels per rack
- Rugged: 3 g Vibration, 50 g Shock, -40 to +70 °C
- Real-time: 1000 I/O scans in < 1 millisecond
- Complete Windows, Linux and RT OS support
- LabVIEW™, MATLAB®, DASyLab™ support and more



DNR-6-1G includes rack/chassis, Dual channel NIC, CPU, Buffer Board, Power Supply, and software. Optional slot covers for empty slots. are also available.

## General Description:

The DNR-6-1G is a compact (3U), rugged Ethernet I/O rack. Though the backplane electronics are identical to our popular PowerDNA "Cube" series, the RACKtangle DNR series provides two Gigabit Ethernet (100/10 Base-T compatible) interfaces and slots for up to 6 I/O boards. Front-loading slots allow the I/O boards to be quickly and easily installed and removed. These capabilities dramatically increase performance and simplify system reconfiguration when necessary. The backplane within the rack contains no active electronic components, ensuring the rack itself has an almost unlimited MTBF. It also means that all active components are on easily replaceable I/O modules, offering an extremely short MTTR in critical applications.

DNR series I/O boards are electronically identical to the DNA boards developed for use in UEI's I/O Cubes. The DNR-6-1G is supported by a rapidly growing complement of I/O boards. The DNR RACKtangle chassis is ideally suited for a wide variety of industrial, aerospace, automotive and laboratory data acquisition and control applications.

The DNR-6-1G provides the 8347 PowerPC CPU, two Ethernet Network Interfaces, indicator lights, timing/trigger interface, configuration ports, backplane buffer and power supply. The bulk of the rack is dedicated to the 6 I/O slots. These slots are populated with I/O modules selected to match your application. With over 30 different I/O boards available, we're sure to have just what your application requires. We currently offer: Analog input boards to measure voltage, current, strain gages, thermocouples and more, Analog output boards with outputs to  $\pm 40V$  or  $\pm 50$  mA, Digital I/O

interfaces for logic and "real-world" signal levels, counters and timers, quadrature encoder inputs, and Communications interfaces for ARINC-429, RS-232/422/485 and the CAN bus.

A variety of Ethernet based communications "modes" provide the interface between the host PC and the DNR rack. Largely transparent to the user and fully compliant with standard Ethernet operation, these communications modes have been optimized for certain application types. The first is simple, single point, programmed I/O. This mode is simple and is suitable for most systems where high speed or precise sample timing are not required. The second mode is the ACB (Advanced Circular Buffer). In ACB mode, data is written to and from buffers on the I/O

boards rather than directly to the Ethernet port. ACB mode is preferred for high speed acquisition/control or where precise timing is required, as the buffers are large enough to ensure data is not lost due to Ethernet timing latencies. The third mode, is DMAP. In DMAP mode, cubes use our patented DAQBIOS Ethernet protocol to ensure deterministic real-time performance and achieve sub-millisecond response times across more than 1000 I/O (analog and/or digital) points. Finally,

there are two high speed messaging modes that allow real-time performance when transferring data to and from any of the communications I/O boards (e.g. the ARINC-429 or CAN-bus interface).

No system is complete without software. The DNR-6 rack is supported by all the popular Windows, Vista, Linux, and Real-time operating systems. The UEIDAQ Framework included with the rack provides a simple

## Controller Block Diagram:

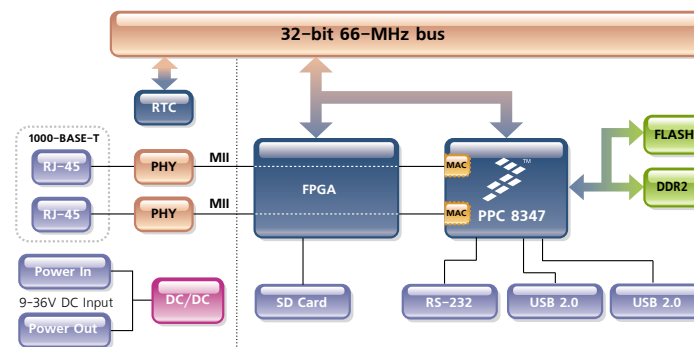

## General Description (continued):

and universal API and supports all common programming languages. The rack is also fully supported by an extensive array of application packages including LabVIEW, MATLAB, DASyLab and more.

The DNR-6 rack offers a wide variety of mounting options. The standard rack is provided with rubber feet which make the DNR-6 ideal for desk or table top applications. A bracket kit allows the cubes to be mounted to a wall or other flat surface or in any standard 19" rack (3U height).

## Technical Specifications:

Standard Interfaces	
To Host Computer	Two independent 1000Base-T Gigabit Ethernet ports (100/10Base-T compatible)
Distance from host	100 meters, max
Config/General	RS-232, 9-pin "D"
Sync	Custom cable to sync multiple racks
I/O Slots Available	
DNR-6-1G	6 slots
Data transfer and communications rates	
Ethernet data transfer rate	20 megabytes per second
Analog data transfer rate	up to 6 megasample per sec (16-bit samples)
DMAP I/O mode	update 1000 I/O channels (analog and/or digital) in less than 1 millisecond, guaranteed
Processor	
CPU	Freescale 8347, 400 MHz, 32-bit
Memory	128 MB (not including on-board Flash)
Status LEDs	Power supplies within spec, One second system heart-beat, Attention, Read/Write, Power, Communications Active
Environmental	
Temp (operating)	Tested to -40 °C to 70 °C
Temp (storage)	-40 °C to 85 °C
Humidity	0 to 95%, non-condensing
Vibration	
(IEC 60068-2-64)	10–500 Hz, 3 g (rms), Broad-band random
(IEC 60068-2-6)	10–500 Hz, 3 g, Sinusoidal
Shock	
(IEC 60068-2-27)	50 g, 3 ms half sine, 18 shocks at 6 orientations; 50 g, 11 ms half sine, 18 shocks at 6 orientations
MTBF	130,000 hours
Physical Dimensions	
DNR-6 series	5.25" x 6.2" x 10.5" (3U in a 19" rack)
Power Requirements	
Voltage	9 - 36 VDC (AC adaptor included)
Fuse	Internal 10 A
Power Dissipation	13 W at 24 VDC (not including I/O boards)
Power Monitoring	
I/O board power	All internal power supplies monitored to ±1% accuracy. All PS voltages may be read by host. LED annunciators indicate out of range
Input current	Monitored by host, LED indicates overcurrent
Input voltage	Monitored by host, LED indicates out of range

## DNR Series Advantages:

### Easy to Configure and Deploy

- Over 30 different I/O boards available
- Over 5 quadrillion possible configurations
- Gigabit Ethernet based (100/10Base-T compatible)
- Bracket kit for mounting to wall or in 19" racks
- Industrial quality rubber feet for solid table-top mounting
- Passive backplane ensures high MTBF and Low MTTR
- Standard "Off-the-shelf" products and delivery

### True Real-time Performance

- 1 msec updates guaranteed with 1000 I/O
- Up to 6 million samples per second
- Use QNX, RTX, RT Linux, RTAI Linux, LabVIEW RT

### Flexible Connectivity

- 1000Base-T with Cat-5 cable
- Supports WIFI / GSM / Cell networks

### Compact Size:

- 5.25" x 6.2" x 10.5"
- 150 analog inputs per rack
- 192 analog outputs per rack
- 288 digital I/O bits per rack
- 48 counter/quadrature channels per rack
- 72 ARINC-429 channels per rack
- 24 RS-232/422/485 ports per rack

### Low Power:

- Less than 13 watts per typical rack (not including I/O)
- AC, 9-36 VDC or battery powered.

### Stand alone and Data Logger Modes

- Upgradeable to UEILogger 600R
- Upgradeable to UEIPAC 600R
- Upgradeable to UEIModbus 600R

### Rugged and Industrial:

- Solid Aluminum construction
- 130,000 hour MTBF
- Operation tested from -40°C to +70°C
- Vibration tested to 3 g, (operating)
- Shock tested to 50 g (operating)
- All I/O isolated from rack and host PC.

### Outstanding Software Support

- Windows, Linux, RT Linux, Windows RT, RTX VXworks and QNX operating systems
- VB, VB .NET, C, C#, C++, J#
- MATLAB, LabVIEW, DASyLab, OPC, ActiveX support

# DNR Layout:

## Protected On/Off Switch

The On/off switch is mounted within two metal shields which ensure the switch will not be inadvertently turned on or off.

## Power Supply Module

Power-In, 9-36V DC either from the DNA-PSU-24-100 (included with the rack), a user-supplied source, or daisychained from another DNR rack. All power supplies are monitored. Power supply status is supplied to the CPU module as well as displayed on annunciator LEDs (see layout below).

## CPU and NIC Module

The DNR series controller and NIC interface are provided in the center slot. This configuration maximizes system noise immunity by reducing the maximum distance an I/O board may be from the CPU. In addition to providing the CPU, this module provides the two Network/Ethernet ports, the two USB 2.0 ports, the serial configuration port, the recessed reset button, the inter-rack sync interface and the SD Card slot.

## Dual Retention Thumb Screws

Dual retention thumb screws ensure the DNR modules remain in their intended positions. A simple module ejector tab allows users to easily remove boards with one hand.

## Passive Backplane

The backplane of the DNR rack contains no active components. This means the DNR chassis itself offers an almost unlimited MTBF. All active components in a DNR system (except cooling fans) are on easily replaced boards.

## I/O Slots

The DNR rack provides 6 I/O slots. All combinations of DNR-series I/O boards are allowed offering over literally trillions of possible configurations. DNR series I/O boards are fully plug-and-play. There is no hardware configuration required. It is recommended that empty slots be covered with blank panels (part number DNR-IO-FILLER available separately) to maintain air flow, reduce EMI, and protect the system from dust accumulation. Your signals may be connected directly to the I/O boards via your custom cabling or take advantage of our wide variety of easy-to-use, external screw terminal panels.

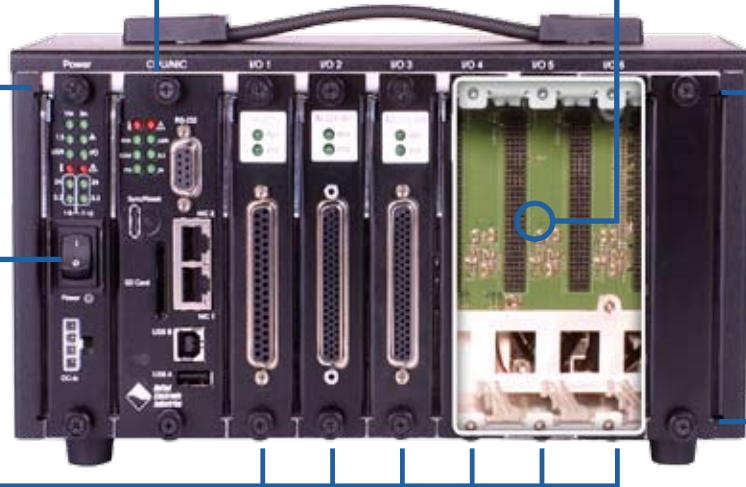

## Power Supply Annunciator LEDs

Spec	ON / OFF	LED	Spec:	ON / OFF
Vin:	OK / Error	Vin	Input I:	OK / Overcurrent
1.5V	OK / Error	1.5	Fans:	On / Off
User controlled, default is off		USR		One flash per second heartbeat
Temp:	Over / OK	Temp	System:	Error / OK
24 V*:	OK / Error	24	24 V**:	OK / Error
3.3 V*	OK / Error	3.3	3.3 V**:	OK / Error
*24 V & 3.3 V for slots 1-3		**24 V & 3.3 V for slots 4-6		

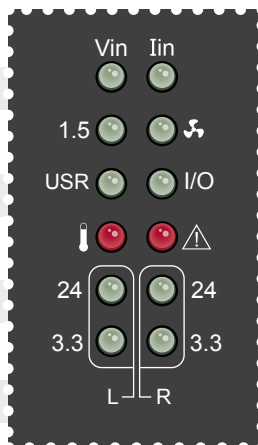

## CPU/NIC Pinouts:

### Power In<sup>1</sup> (molex)

1	+VIN
2	GND
3	GND
4	+VIN

### Serial (RS-232)

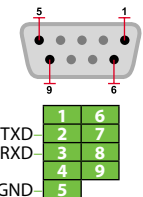

### Synchronization

1	+5 V
2	+5 V
3	Gnd
4	Sync Out 2
5	Gnd
6	Sync In 2
7	Gnd
8	Sync Out 1
9	Gnd
10	Sync In 1

<sup>1</sup>Mating connector available from Digikey, Molex PN 39-01-4040

<sup>3</sup>Internal pull-up, start/stop trigger should connect SYNC\_IN with SYNC\_GND

# CPU and NIC Interface

## Status LEDs

These LED indicators display the status of a variety of internally monitored parameters including: Internal temperature, system self-test status, bus activity, SD card activity as well as providing indication that required CPU/NIC power supply voltages are within specifications. A user controllable USR LED can be controlled by the application program and by a service technician to confirm he/she is working on the correct rack in multiple rack installations.

## Sync Connector

High-speed Cube-to-Cube synchronization connector. This connector allows triggers or clocks to be shared among racks. Two racks may be connected together directly or larger systems may take advantage of the DNA-SYNC interface to share timing signals among many racks.

## SD Card Slot

Secure Digital (SD) Card slot for onboard data storage. The SD Card is used as the data storage media in the UEILogger series. It also stores both data and Linux embedded programs deployed on the rack using the soon to be released embedded toolkit. Supports FAT12, FAT16 and FAT32 file systems.

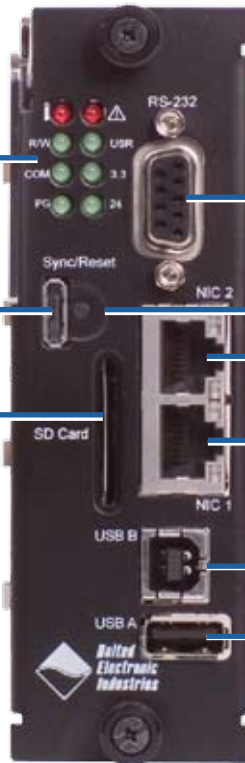

## Serial Port

The serial port is used primarily for system setup and configuration. The rack may be configured from any serial terminal running at 57,600 baud/8 data bits/no parity/1 stop bit. From a terminal program you can, for instance, change the IP address from the default, if necessary. You also download updated firmware through the serial port. The serial port is usable for RS-232 communications. For users without a convenient serial port, a USB to serial converter provides a simple and inexpensive interface

## Reset Button

Recessed to prevent accidental activation, this button resets the CPU layer for activities such as downloading and installing new firmware for the DNR rack. It may also be used to start/stop logging when the rack is configured as a UEILogger 600R.

## Network Connectors

Each NIC interface includes two independent Gigabit Ethernet ports. The 1000/100/10Base-T interface allows the rack to be installed up to 100 Meters from your host PC. A 100-Base FX fiber optic interface is available as an option and allows the rack to be mounted up to 2 km from the host using multi-mode fiber or up to 20 km from the host via single-mode fiber cable.

## USB 2.0 [not yet implemented]

The DNR-6-1G will eventually provide two high speed USB 2.0 interfaces. One of the USB ports is configured as a controller while the other is configured as a slave port.

# Software Support

## WINDOWS / VISTA

UEIDAQ Framework Library Architecture

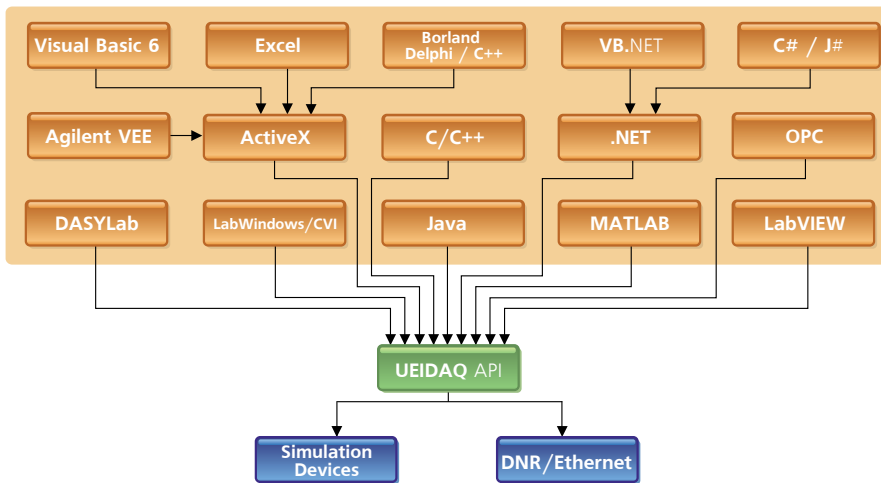

## Linux & REALTIME

Operating Systems/Extensions

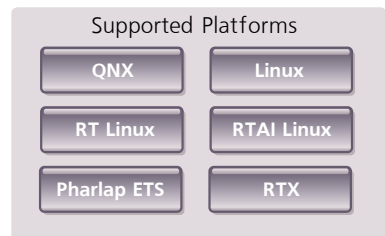

## Ordering Guide:

Part Number	Description
<b>DNR Racks (includes UEIDAQ Framework software, universal AC power supply, serial and Ethernet cables)</b>	
DNR-6-1G	6 slot, 3U, 1000Base-T based DNR series Gigabit Ethernet-based DAQ and Control rack
DNR-IO-FILLER	Optional (but recommended) I/O slot fillers to cover unused slots

Specifications subject to change without notice